

Write your name here

Surname

Other names

Pearson Edexcel Certificate
Pearson Edexcel
International GCSE

Centre Number

--	--	--	--	--

Candidate Number

--	--	--	--

Mathematics A

Paper 3H



Higher Tier

Thursday 26 May 2016 – Morning
Time: 2 hours

Paper Reference
4MA0/3H
KMA0/3H

You must have:

Ruler graduated in centimetres and millimetres, protractor, compasses, pen, HB pencil, eraser, calculator. Tracing paper may be used.

Total Marks

Instructions

- Use **black** ink or ball-point pen.
- **Fill in the boxes** at the top of this page with your name, centre number and candidate number.
- Answer **all** questions.
- Without sufficient working, correct answers may be awarded no marks.
- Answer the questions in the spaces provided
– *there may be more space than you need.*
- **Calculators may be used.**
- You must **NOT** write anything on the formulae page.
Anything you write on the formulae page will gain NO credit.

Information

- The total mark for this paper is 100.
- The marks for **each** question are shown in brackets
– *use this as a guide as to how much time to spend on each question.*

Advice

- Read each question carefully before you start to answer it.
- Check your answers if you have time at the end.

Turn over ►

P45841A

©2016 Pearson Education Ltd.

1/1/1/1/



PEARSON

**International GCSE MATHEMATICS
FORMULAE SHEET – HIGHER TIER**

Pythagoras' Theorem

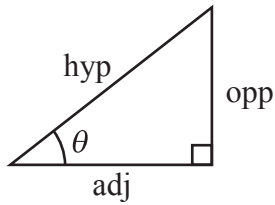
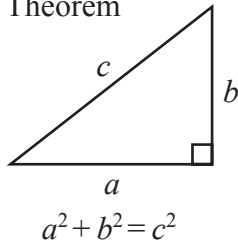

adj = hyp \times cos θ
opp = hyp \times sin θ
opp = adj \times tan θ

or $\sin \theta = \frac{\text{opp}}{\text{hyp}}$

$\cos \theta = \frac{\text{adj}}{\text{hyp}}$

$\tan \theta = \frac{\text{opp}}{\text{adj}}$

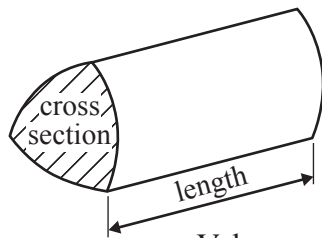

Volume of prism = area of cross section \times length

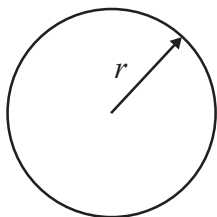

Circumference of circle = $2\pi r$

Area of circle = πr^2

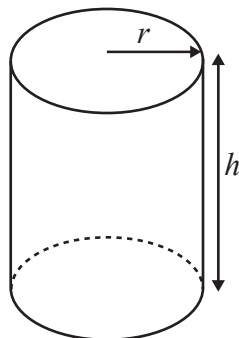

Volume of cylinder = $\pi r^2 h$

Curved surface area of cylinder = $2\pi r h$

Volume of cone = $\frac{1}{3} \pi r^2 h$

Curved surface area of cone = $\pi r l$

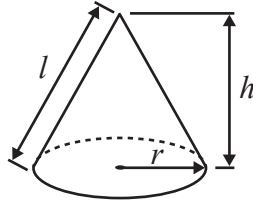

Volume of sphere = $\frac{4}{3} \pi r^3$

Surface area of sphere = $4\pi r^2$

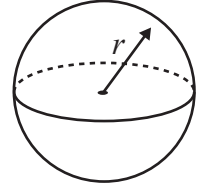

In any triangle ABC

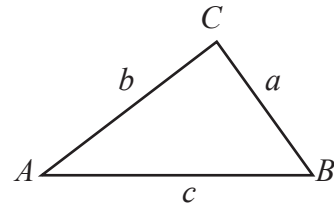

Sine rule: $\frac{a}{\sin A} = \frac{b}{\sin B} = \frac{c}{\sin C}$

Cosine rule: $a^2 = b^2 + c^2 - 2bc \cos A$

Area of triangle = $\frac{1}{2} ab \sin C$

Area of a trapezium = $\frac{1}{2}(a + b)h$

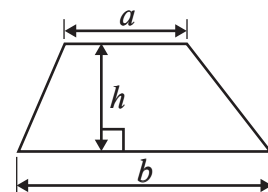

The Quadratic Equation
The solutions of $ax^2 + bx + c = 0$,
where $a \neq 0$, are given by

$$x = \frac{-b \pm \sqrt{b^2 - 4ac}}{2a}$$



DO NOT WRITE IN THIS AREA

DO NOT WRITE IN THIS AREA

DO NOT WRITE IN THIS AREA

Answer ALL TWENTY TWO questions.

Write your answers in the spaces provided.

You must write down all the stages in your working.

1 Here are the ingredients needed to make 12 muffins.

Ingredients to make 12 muffins
300 g flour
150 g sugar
250 ml milk
100 g butter
2 eggs

Sarah makes 60 muffins.

(a) Work out how much sugar she uses.

..... g
(2)

James makes some muffins.

He uses 625 ml of milk.

(b) How many muffins did he make?

.....
(2)

(Total for Question 1 is 4 marks)



2 $a = -5$
 $c = -2$

(a) Work out the value of $2a^2 + 6c$

.....
(2)

There are 4 pens in a small box of pens.
There are 10 pens in a large box of pens.

Ami buys x small boxes of pens and y large boxes of pens.
She buys a total of T pens.

(b) Write down a formula for T in terms of x and y .

.....
(3)

(Total for Question 2 is 5 marks)



DO NOT WRITE IN THIS AREA

DO NOT WRITE IN THIS AREA

DO NOT WRITE IN THIS AREA

3 The table shows information about the number of visits each of 40 adults made to the gym last week.

Number of visits to the gym	Frequency
0	4
1	3
2	12
3	5
4	8
5	5
6	2
7	1

Work out the mean of the number of visits to the gym.

(Total for Question 3 is 3 marks)

- 4 $A = \{2, 4, 6, 8, 10, 12, 14\}$
 $B = \{1, 3, 5, 7, 9, 11, 13\}$
 $C = \{3, 6, 9, 12\}$

(a) List the members of the set

(i) $A \cap C$

(ii) $A \cup C$

(2)

(b) Explain why $A \cap B = \emptyset$

(1)

(Total for Question 4 is 3 marks)



5 On the grid, draw the graph of $y = 3x - 5$ for values of x from -2 to 3

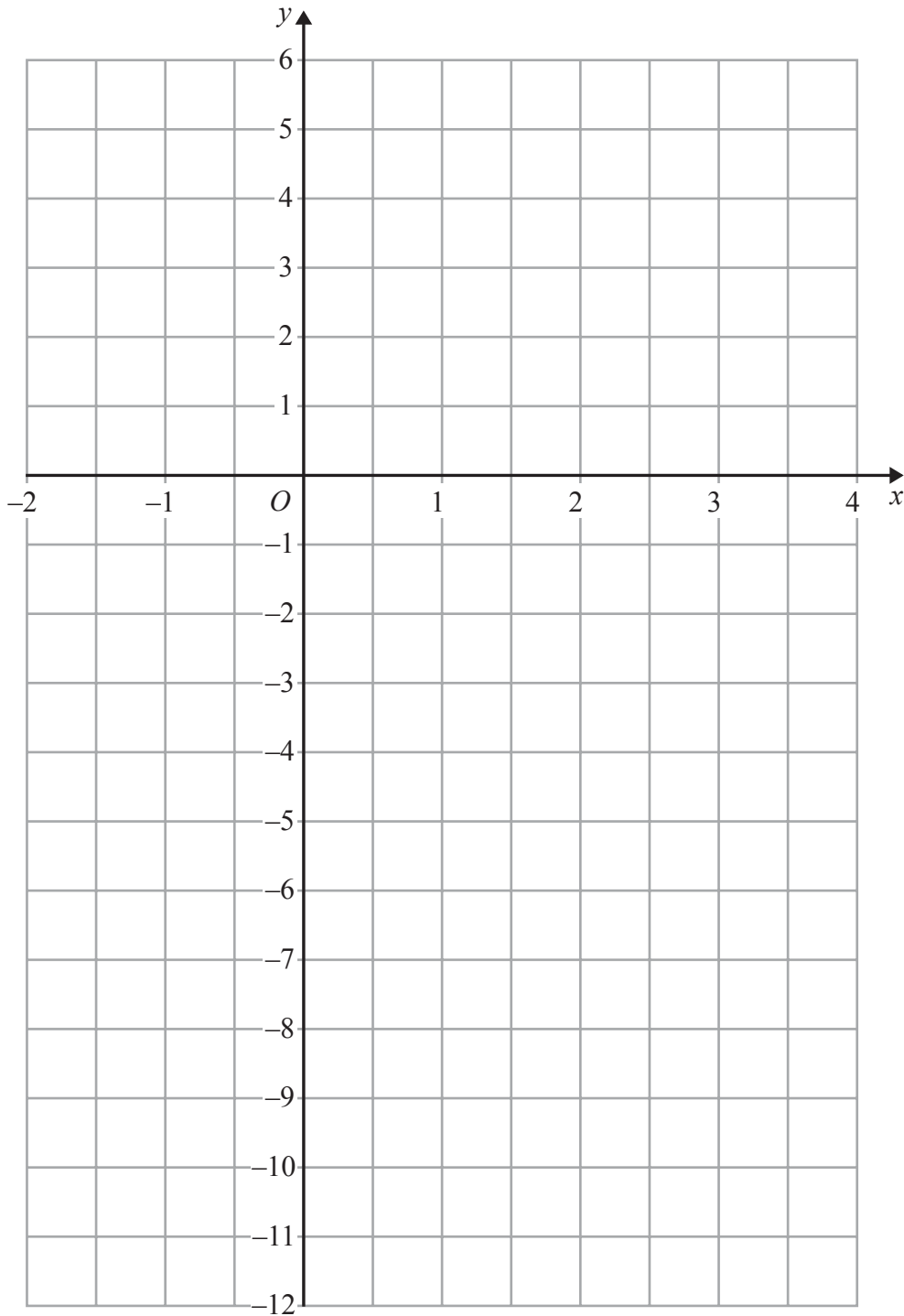

(Total for Question 5 is 4 marks)

DO NOT WRITE IN THIS AREA

DO NOT WRITE IN THIS AREA

DO NOT WRITE IN THIS AREA



DO NOT WRITE IN THIS AREA

DO NOT WRITE IN THIS AREA

DO NOT WRITE IN THIS AREA

6 (a) Show that $\frac{3}{10} + \frac{2}{15} = \frac{13}{30}$

(2)

(b) Show that $2\frac{5}{8} \div 1\frac{1}{6} = 2\frac{1}{4}$

(3)

(Total for Question 6 is 5 marks)



7 (a) Factorise $3y^2 + 2y$

.....
(1)

(b) Expand and simplify $(x - 9)(x + 2)$

.....
(2)

(c) (i) Solve $6k + 5 < 20$

(ii) n is an integer and $6n + 5 < 20$

Write down the largest possible value of n

.....
(3)

(d) Simplify fully $\frac{28x^5y^3}{4xy^2}$

.....
(2)

(Total for Question 7 is 8 marks)



DO NOT WRITE IN THIS AREA

8

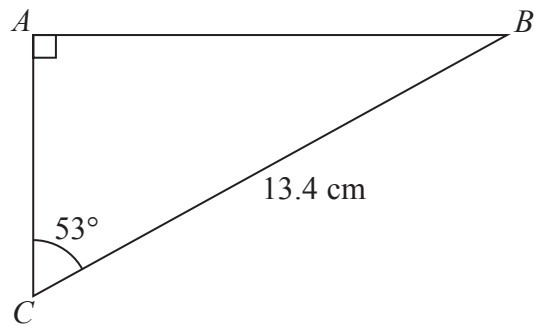

Diagram **NOT** accurately drawn

Work out the length of AB .
Give your answer correct to 1 decimal place.

..... cm

(Total for Question 8 is 3 marks)



9 Bhavin, Max and Imran share 6000 rupees in the ratios 2 : 3 : 7

Imran then gives $\frac{3}{5}$ of his share of the money to Bhavin.

What percentage of the 6000 rupees does Bhavin now have?

Give your answer correct to the nearest whole number.

DO NOT WRITE IN THIS AREA

DO NOT WRITE IN THIS AREA

DO NOT WRITE IN THIS AREA

..... %

(Total for Question 9 is 5 marks)



DO NOT WRITE IN THIS AREA

DO NOT WRITE IN THIS AREA

DO NOT WRITE IN THIS AREA

10 The diagram shows a circle inside a rectangle.

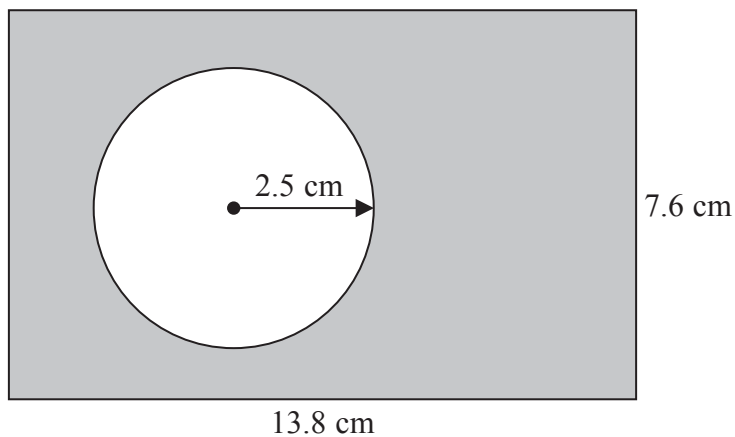

Diagram **NOT** accurately drawn

Work out the area of the shaded region.
Give your answer correct to 3 significant figures.

..... cm²

(Total for Question 10 is 3 marks)



11 The frequency table shows information about the weights of 80 adults.

Weight (w kg)	Frequency
$40 < w \leq 50$	4
$50 < w \leq 60$	7
$60 < w \leq 70$	21
$70 < w \leq 80$	21
$80 < w \leq 90$	18
$90 < w \leq 100$	7
$100 < w \leq 110$	2

(a) Complete the cumulative frequency table.

Weight (w kg)	Cumulative frequency
$40 < w \leq 50$	4
$40 < w \leq 60$	
$40 < w \leq 70$	
$40 < w \leq 80$	
$40 < w \leq 90$	
$40 < w \leq 100$	
$40 < w \leq 110$	

(1)



(b) On the grid, draw a cumulative frequency graph for your table.

(2)

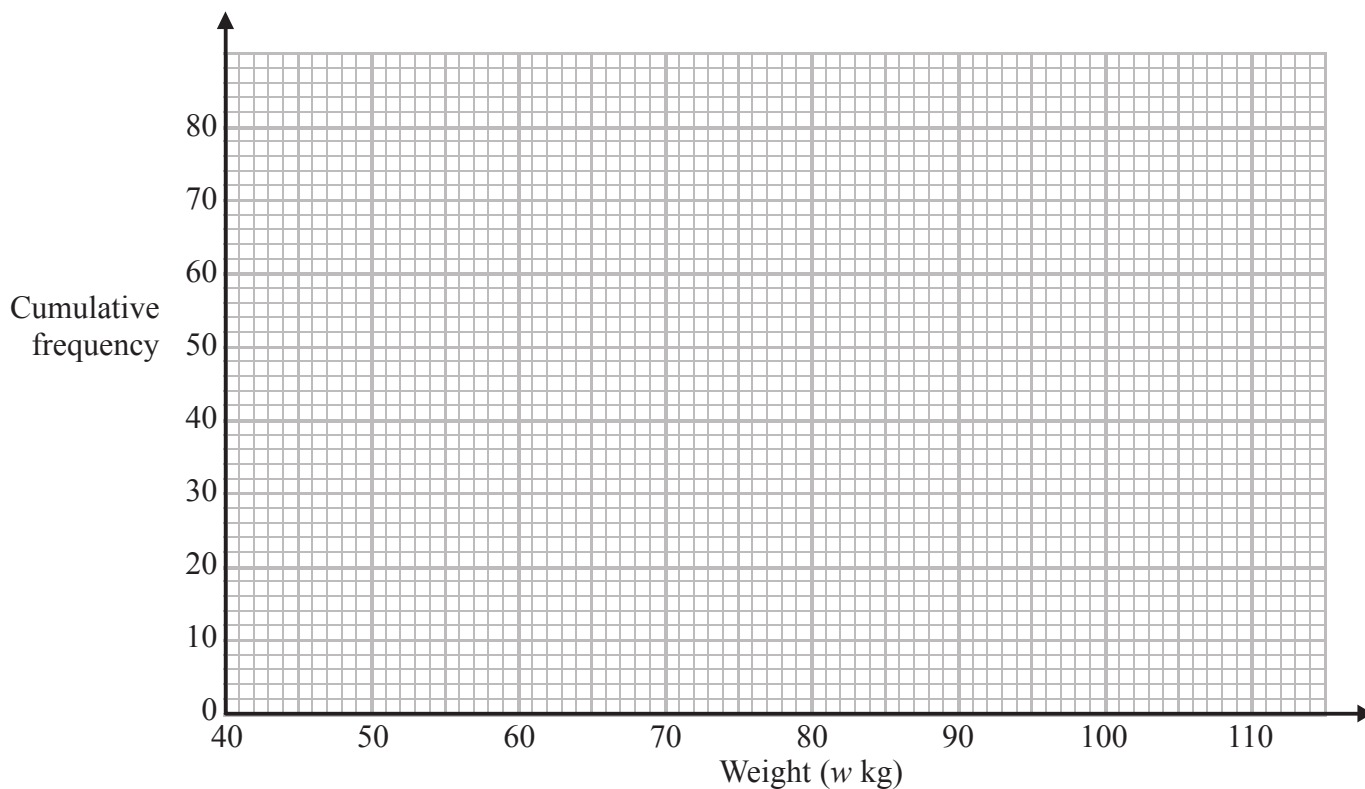

(c) Use your graph to find an estimate for the number of adults with weight more than 85 kg.

.....
(2)

(d) Use your graph to find an estimate for the interquartile range of the weights of the adults.

..... kg
(2)

(Total for Question 11 is 7 marks)

DO NOT WRITE IN THIS AREA

DO NOT WRITE IN THIS AREA

DO NOT WRITE IN THIS AREA



12 Solve the simultaneous equations

$$4x + 5y = 13$$

$$3x - 2y = 27$$

Show clear algebraic working.

$$x = \dots\dots\dots$$

$$y = \dots\dots\dots$$

(Total for Question 12 is 4 marks)

DO NOT WRITE IN THIS AREA

DO NOT WRITE IN THIS AREA

DO NOT WRITE IN THIS AREA



DO NOT WRITE IN THIS AREA

DO NOT WRITE IN THIS AREA

DO NOT WRITE IN THIS AREA

13 The straight line **L** passes through the points $(-2, 3)$ and $(6, 9)$

Find an equation of the line that is parallel to **L** and passes through the point $(5, -1)$
Give your answer in the form $ax + by = c$ where a, b and c are integers.

.....
(Total for Question 13 is 5 marks)



14 A particle is moving along a straight line.
The fixed point O lies on this line.
The displacement of the particle from O at time t seconds is s metres where

$$s = 2t^3 - 12t^2 + 7t$$

(a) Find an expression for the velocity, v m/s, of the particle at time t seconds.

$v = \dots\dots\dots$ (2)

(b) Find the time at which the acceleration of the particle is instantaneously zero.

$\dots\dots\dots$ seconds (2)

(Total for Question 14 is 4 marks)



DO NOT WRITE IN THIS AREA

DO NOT WRITE IN THIS AREA

DO NOT WRITE IN THIS AREA

15 The diagram shows two mathematically similar vases, **A** and **B**.

Diagram **NOT** accurately drawn



A



B

Vase **A** has a surface area of 120 cm^2

Vase **B** has a surface area of 750 cm^2 and a volume of 1600 cm^3

Work out the volume of vase **A**.

..... cm^3

(Total for Question 15 is 3 marks)



16 $ABCDEFGH$ is a cuboid.

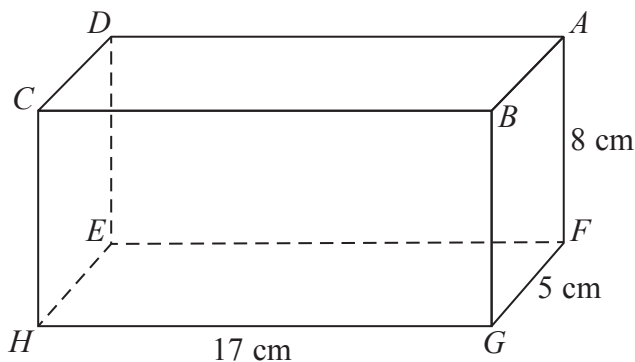

Diagram **NOT** accurately drawn

The cuboid has

- length 17 cm
- width 5 cm
- height 8 cm

Work out the size of the angle that AH makes with the plane $EFGH$.
Give your answer correct to 1 decimal place.

DO NOT WRITE IN THIS AREA

DO NOT WRITE IN THIS AREA

DO NOT WRITE IN THIS AREA

(Total for Question 16 is 4 marks)



DO NOT WRITE IN THIS AREA

DO NOT WRITE IN THIS AREA

DO NOT WRITE IN THIS AREA

17 The diagram shows a trapezium.

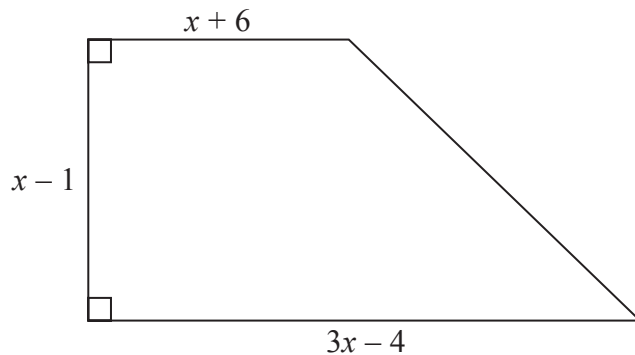

Diagram NOT accurately drawn

All measurements on the diagram are in centimetres.

The area of the trapezium is 119 cm^2

(i) Show that $2x^2 - x - 120 = 0$

(ii) Find the value of x .
Show your working clearly.

$x = \dots\dots\dots$

(Total for Question 17 is 6 marks)



18 Make t the subject of the formula $m = \frac{t + 1}{t - 3}$

DO NOT WRITE IN THIS AREA

DO NOT WRITE IN THIS AREA

DO NOT WRITE IN THIS AREA

(Total for Question 18 is 4 marks)



19

Diagram **NOT**
accurately drawn

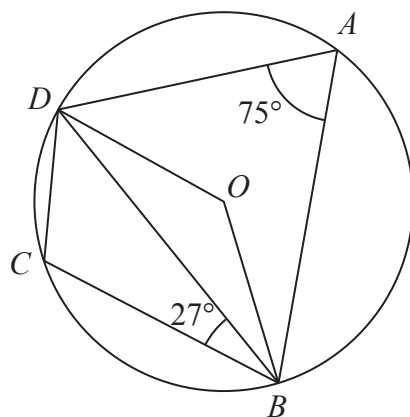

A , B , C and D are points on a circle, centre O .

Angle $DAB = 75^\circ$

Angle $DBC = 27^\circ$

Work out the size of angle ODC .

.....
(Total for Question 19 is 4 marks)



20 A metal cube has sides of length 4.5 cm, correct to the nearest 0.5 cm.

The cube is melted down and the metal is used to make small spheres.
Each sphere has a radius of 3 mm, correct to the nearest millimetre.

Work out the greatest number of spheres that could be made from the metal.
Show your working clearly.

DO NOT WRITE IN THIS AREA

DO NOT WRITE IN THIS AREA

DO NOT WRITE IN THIS AREA

(Total for Question 20 is 5 marks)



DO NOT WRITE IN THIS AREA

DO NOT WRITE IN THIS AREA

DO NOT WRITE IN THIS AREA

21 There are 9 counters in a bag.
There is a number on each counter.



Kal takes at random 3 counters from the bag.

He adds together the numbers on the 3 counters to get his Total.

Work out the probability that his Total is 6

(Total for Question 21 is 5 marks)



22 The diagram shows a pentagon.

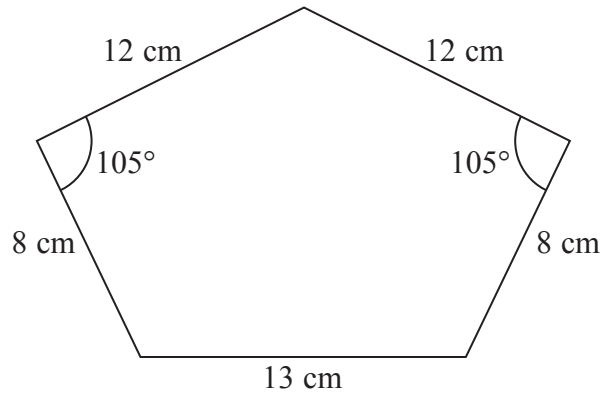

Diagram **NOT** accurately drawn

Work out the area of the pentagon.
Give your answer correct to 3 significant figures.

..... cm²

(Total for Question 22 is 6 marks)

TOTAL FOR PAPER IS 100 MARKS

DO NOT WRITE IN THIS AREA

DO NOT WRITE IN THIS AREA

DO NOT WRITE IN THIS AREA

